

Designing and Analysis of Hydrogen Power Vehicle

Sudip Kachhia

UG Student

*Department of Mechanical Engineering
Gujarat Technological University*

Yamal Sarvaiya

UG Student

*Department of Mechanical Engineering
Gujarat Technological University*

Abstract

The hydrogen powered vehicle works on the Spark Ignition Engine so the vehicle can run with the hydrogen gas along with petrol. A system for generation of hydrogen gas by electrolysis of water for the fueling of an engine is disclosed. The system comprises a power regulator to regulate the flow of an electric current from a battery source to hydrogen generation cell provided in communication with the vehicle engine. The hydrogen generation cell has a positive side and a negative side defined by a partition, each of the positive side and the negative side includes a polarity of electricity conductors. The electricity conductors on the positive side receive the electric current in the hydrogen generation cell, on passing the electric current the water in the water tank undergoes electrolysis to generate oxygen gas at the positive side and hydrogen gas at the negative side, the hydrogen gas is then supplied to the engine via the hydrogen flow path.

Keywords: Hydro Power, High Efficiency, Batter Mileage, Low Pollution, Fuel

I. INTRODUCTION

A. Problem Summary

- Environmental Hazards: Environmental pollution is one of the major disadvantages of fossil fuels. It is a known fact that carbon dioxide, gas released when fossil fuels are burnt, is one of the primary gas responsible for global warming.
- Rising Prices: Middle-east countries have huge reserves of oil and natural gas and India is dependent on them for constant supply of these fuels. Organization of the Petroleum Exporting Countries (OPEC) is a group of 13 countries including Iran, Iraq, Kuwait, Qatar, Saudi Arabia and UAE. They are responsible for 40 percent of the world's oil production and hold the majority of the world's oil reserves, according to the Energy Information Administration (EIA). OPEC constantly monitors the volume of oil consumed and then adjusts its own production to maintain its desired barrel price. This results in worldwide price fluctuation.
- Acid Rain: Sulphur dioxide is one of the pollutants that is released when fossil fuels are burnt and is a main cause of acid rain. Acid rain can lead to destruction of monuments made up of brickwork or marbles. Even crops can be affected due to acidification of loams.
- Effect on Human Health: Pollution from vehicles can cause serious environmental hazards. Pollution related diseases range from mild to severe and can significantly affect one's quality of life. Air pollution can result in asthma, chronic obstructive pulmonary disorder and lung cancer. Long-term exposure may increase respiratory infections in general population. Children and the elderly are most vulnerable to fine particulate matter and other airborne toxicants.
- Non-Renewable: As of today, fossil fuels are being extracted at an exorbitant rate to meet the gap between demand and supply and it is estimated that they will be finished in next 30-40 years. Since they are non-renewable, it is more likely that fuel expenses will face a steep hike in near future.

B. Introduction

- Hydrogen, as a fuel, presents an excellent substitute to fossil fuels due to current environmental concerns and a bid to reduce oil dependency. Hydrogen can be produced from a range of sources and its chemical reaction in air does not produce any greenhouse gas emissions. Compared to gasoline, hydrogen has more energy per unit mass, a higher flame speed, wider flammability limits and a lower minimum ignition energy and these unique properties make hydrogen an attractive alternative in the transportation sector. The hydrogen and fuel cell power based technologies that are rapidly emerging can now be exploited to initiate a new era of propulsion systems for small commuter vehicles.
- These technologies can also be developed for the future replacement of fossil fuel engines in vehicles. Hydrogen is expected to provide the fueling source on the medium term and for use in common applications. Fuel cells could become the main power source for small general vehicles or could replace several internal subsystems on transport vehicles.

- Hydrogen based fuel cell automotive system designs are expected to facilitate the gasoline fuel system in automobile applications in the near-term. The replacement of combustion engines with hydrogen fuel cells powered vehicles can guarantee a massive reduction of pollution, (since the only emission produced by a fuel cell is water) and noise pollution.
- Nevertheless, the available fuel cell technologies need substantial improvements to meet safe operational requirements in terms of efficiency, reliability, performance, mass/volume, cost and lifetime at any road conditions and under high and low ambient temperatures on the ground.

C. Aim and Objectives

- This project was developed to study about the Hydrogen driven vehicle using electrolysis process to generate hydrogen from water. The main purposes of this project are listed below:-
- A hydrogen powered vehicle is an automobile that hypothetically derives its energy directly from water. Hydrogen powered vehicle have been the subject of numerous international patents, newspaper and popular science magazine articles, local television news coverage, and websites.
- These vehicles may be claimed to produce fuel from water on board with just electric energy input, or may be a hybrid claiming to derive some of its energy from water in addition to a conventional source (such as gasoline).
- The fuel economy of an automobile is the fuel efficiency relationship between the distance traveled and the amount of fuel consumed by the vehicle. Consumption can be expressed in terms of the distance travelled per unit volume of fuel consumed. Since fuel consumption of vehicles is a significant factor in air pollution, and since importation of motor fuel can be a large part of a nation's foreign trade, many countries impose requirements for fuel economy.
- The implementation of hydrogen generator cell in a vehicle can help in the fuel consumption reduction. Different measurement cycles are used to approximate the actual performance of the vehicle. The energy in fuel is required to overcome various losses (wind resistance, tire drag, and others) in propelling the vehicle, and in providing power to vehicle systems such as ignition or air conditioning.
- Using an on-demand hydrogen generator cell may safely produce hydrogen gas for the vehicle's fueling. The hydrogen generator cell would provide enough hydrogen gas by the electrolysis of water that would extremely reduce the requirement of gasoline, which would cause very great reduction in the pollution through emission.
- Mostly the pure oxygen is released through the emission. Also the consumption of gasoline is reduced at a great extent so the fuel economy is increased successfully.

D. Problem Specifications

- In today's world there are many problems caused due to the increasing number of vehicle. The main problems and their remedies are listed below:
- The amount of Pollution has increased at a great extent. By installing a hydrogen generation cell in a vehicle leads to produce hydrogen and oxygen from water, this hydrogen is to be used as fuel in the engine and the oxygen produced is released to the environment which is good for the environment.
- The most of the fuel we use is imported from the other countries which is measured by the Organization of the Petroleum Exporting Countries (OPEC) and accordingly the prices are fluctuating, which causes the high spends for people's daily use of fuels. Thus by implementing the use of hydrogen as fuel by installing hydrogen generator kit in vehicle would lead to reduced fossil fuel consumption.
- Now a days the global warming is occurring in the world due to high rates of pollutants produced by human activities. Among them the fuels burnt in vehicles is also an important cause. So the global warming can be reduced with the use of non-polluting vehicles such as an electric vehicle or fuel cell vehicle.

II. HYDROGEN PROCESS DESIGN

A. Summary of Electrolytic Hydrogen Production

- Key Word: Economics of Electrolysis; Electrolytic Hydrogen Production; Techno-economic Analysis of Electrolysis.
- Abstract: Hydrogen is available in surplus as a by-product in several industrial processes in petroleum refineries or chlor alkali industries. Hydrogen can also be produced using off-peak electricity mainly by improving the plant load factor of the power stations in the country. Hydrogen can also be produced by biophotolysis which utilizes leaving systems to split water into hydrogen and oxygen. Hydrogen in small quantities can be produced by partial oxidation of hydrocarbons and electrolysis of water. Electrolysis is a very clean and reliable process to produce high purity hydrogen.
- Technology Description:
- Hydrogen is produced via electrolysis by passing electricity through two electrodes in water. The water molecule is split and produces oxygen at the anode and hydrogen at the cathode.
- Three types of industrial electrolysis units are being produced today. Two involve an aqueous solution of potassium hydroxide (KOH), which is used because of its high conductivity, and are referred to as alkaline electrolyzers. These units

can be either unipolar or bipolar. The unipolar electrolyzer resembles a tank and has electrodes connected in parallel. A membrane is placed between the cathode and anode, which separate the hydrogen and oxygen as the gasses are produced, but allows the transfer of ions. The bipolar design resembles a filter press. Electrolysis cells are connected in series, and hydrogen is produced on one side of the cell, oxygen on the other. Again, a membrane separates the electrodes.

- The third type of electrolysis unit is a Solid Polymer Electrolyte (SPE) electrolyzer. These systems are also referred to as PEM or Proton Exchange Membrane electrolyzers. In this unit the electrolyte is a solid ion conducting membrane as opposed to the aqueous solution in the alkaline electrolyzers. The membrane allows the H⁺ ion to transfer from the anode side of the membrane to the cathode side, where it forms hydrogen. The SPE membrane also serves to separate the hydrogen and oxygen gasses, as oxygen is produced at the anode on one side of the membrane and hydrogen is produced on the opposite side of the membrane.

- The efficiency of electrolysis (E) is defined by the following equation

$$E = \frac{\text{Hydrogen produced (meter cube)} \times F \times 100}{\text{Power input by cells (KW hr)}}$$

- Based on experimental studies, value of F can be chosen as 3.3 kW hr/meter cube.
- Regardless of the technology, the overall electrolysis reaction is the same:

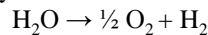

However, reaction at each electrode differs between PEM and alkaline systems. In a PEM system the reactions at the electrodes are:

PEM Hydrogen Production at the Cathode

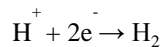

PEM Oxygen Production at the Anode

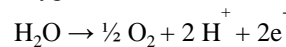

- In an alkaline system the reaction at each electrode are

Alkaline Hydrogen Production at the Cathode

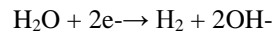

Alkaline Oxygen Production at the Anode

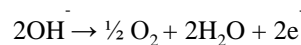

B. Process Design

A typical electrolysis process diagram is shown in Figure 1. Note that different processes will use different pieces of equipment. For example, PEM units will not require the KOH mixing tank, as no electrolytic solution is needed for these electrolyzers. Another example involves water purification equipment. Water quality requirements differ across electrolyzers. Some units include water purification inside their hydrogen generation unit, while others require an external deionizer or reverse osmosis unit before water is fed to the cell stacks. For systems that do not include a water purifier, one is added in the process flow. A water storage tank may be included to ensure that the process has adequate water in storage in case the water system is interrupted.

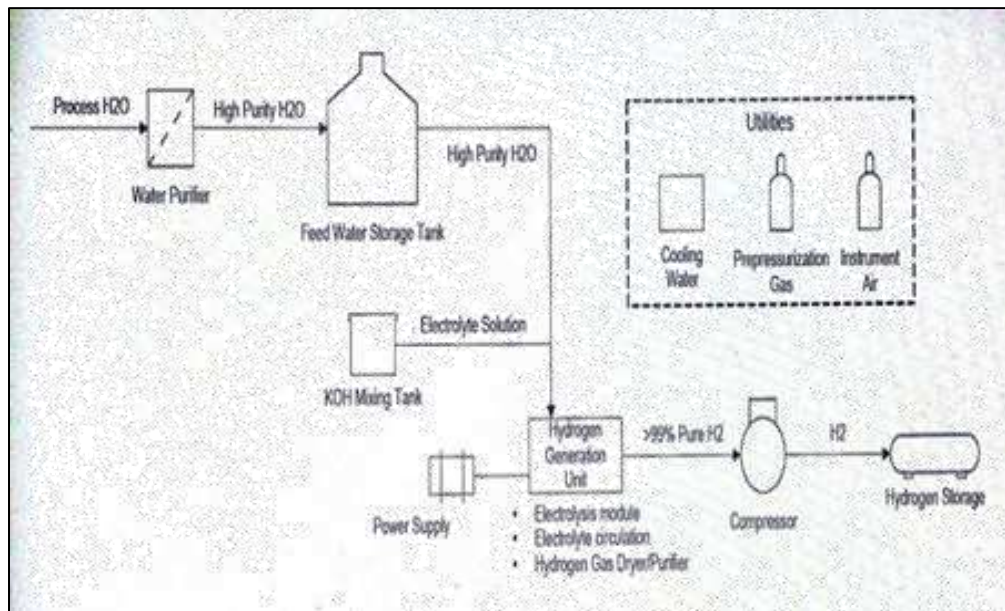

Fig. 1: Process Flow Diagram

- Each system has a hydrogen generation unit that integrates the electrolysis stack, gas purification and dryer, and heat removal. Electrolyte circulation is also included in the hydrogen generation unit in alkaline systems. The integrated system is usually enclosed in a container or is installed as a complete package. Although hydrogen storage and compression are included in the process diagram below, for purposes of this analysis, hydrogen storage is not included. It is assumed that as the hydrogen is produced it is fed directly into a pipeline or truck. In addition, note that there is no oxygen compression and storage.
- Typical utilities that the electrolysis systems need include electricity for electrolysis and other peripheral equipment; cooling water for the hydrogen generation unit; pre-pressurization gas; and inert gas.

III. INTERNAL COMBUSTION ENGINE FUNDAMENTALS

- A typical ICE such as that generally used in automobiles, trucks and other similar vehicles uses hydrocarbon fuels for combustion. It is well known that the burning of such fuels is not one hundred percent efficient and further produces large amount of pollutants as a byproduct of the combustion process.

A. Spark Ignition Engine

- Figure is a schematic diagram of a four-stroke SI engine. The SI engine relies on a spark plug to ignite a volatile air-fuel mixture as the piston approaches top dead center (TDC) on the compression stroke. This mixture may be supplied from a carburetor, a single throttle-body fuel injector, or by individual fuel injectors mounted in the intake port of each cylinder. One combustion cycle involves two revolutions of the crankshaft and thus four strokes of the piston, referred to as the intake, compression, power, and exhaust strokes. Intake and exhaust valves control the flow of mixture and exhaust gases into and out of the cylinder, and an ignition system supplies a spark-inducing high voltage to the spark plug at the proper time in the cycle to initiate combustion. On the intake stroke, the intake valve opens and the descending piston draws a fresh combustible charge into the cylinder. During the compression stroke, the intake valve closes and the fuel-air mixture is compressed by the upward piston movement. The mixture is ignited by the spark plug, somewhat before TDC.

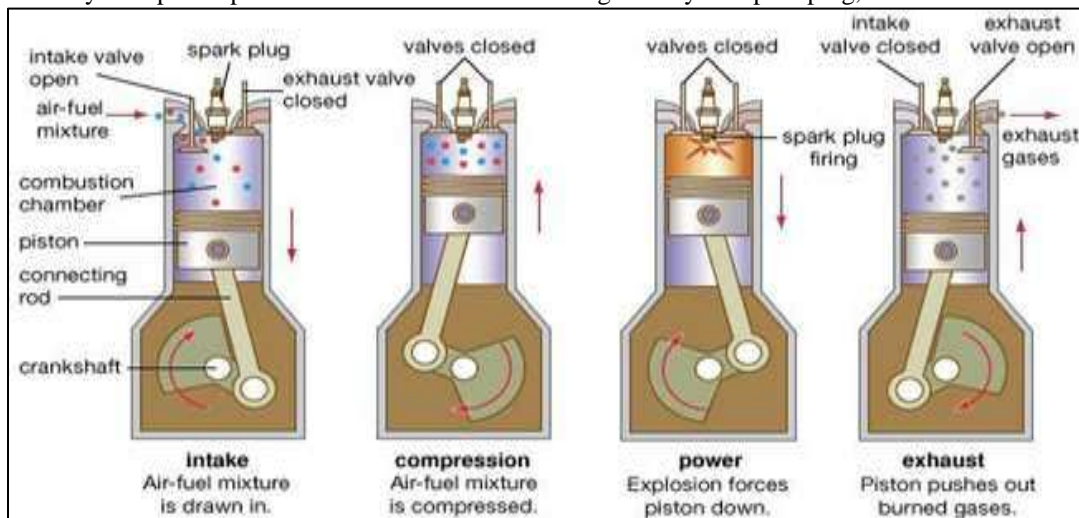

Fig. 2: Cross-section schematic of a four stroke SI engine

The rapid premixed homogeneous combustion process causes a sharp increase in cylinder temperature and pressure that forces the piston down for the power stroke. Near bottom dead center (BDC) the exhaust valve opens and the cylinder pressure drops rapidly to near atmospheric. The piston then returns to TDC, expelling the exhaust products. At TDC, the exhaust valve closes and the intake valve opens to repeat the cycle again (Kahraman, 2005; from Heywood, 1998).

In SI engines the air and fuel are usually mixed together in the intake manifold using either a carburetor or fuel injection system. In automobile applications, the temperature of the air entering the intake system is controlled by mixing ambient air with air heated by the exhaust manifold. For gasoline the ratio of mass flow of air to mass flow of fuel must be held around 15 to ensure reliable combustion. The carburetor meters an appropriate fuel flow for the engine air flow in the following manner. The air flow through the venturi (a converging-diverging nozzle) sets up a pressure difference between the venturi inlet and throat which is used to meter an appropriate amount of fuel from the float chamber. Just below the venturi is a throttle valve or plate which controls the combined air and fuel flow as shown in figure 3.

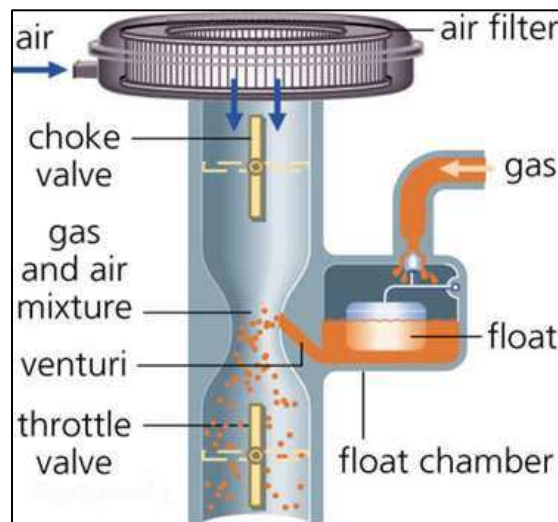

Fig. 3: Cross section of a single barrel carburettor

- The intake flow is throttled to below atmospheric pressure by reducing the flow area according to the power required. The maximum power is obtained when the throttle is wide open. The intake manifold is usually heated to promote faster evaporation of the liquid fuel thus obtaining a more uniform fuel distribution.
- Fuel injection into the intake manifold or inlet port is a widely used alternative to a carburetor. With port injection, fuel is injected through individual injectors from a low-pressure fuel supply into each intake port. There are several different types of injection systems. Mechanical injection in which an injection pump driven by the engine continuously injects fuel to the inlet port and electronically controlled injection where an electronic control unit (ECU) measures the air flow rate and accordingly supplies fuel.

B. Valve Timing

- The camshaft that comes with the gasoline engine was designed to produce its maximum power at high engine speeds. It was ground to have 48 degrees of valve overlap and 268 degrees of duration with a 0.74-inch valve lift at .050-inch tappet lift. This type of grind will typically produce excellent airflow high volumetric efficiency, at the expense poor air dynamics at the lower engine speeds. For gasoline fueled engines, this typically means low efficiencies, poor idle and high emissions. For racing purposes, this compromise for high engine speeds is worth it.

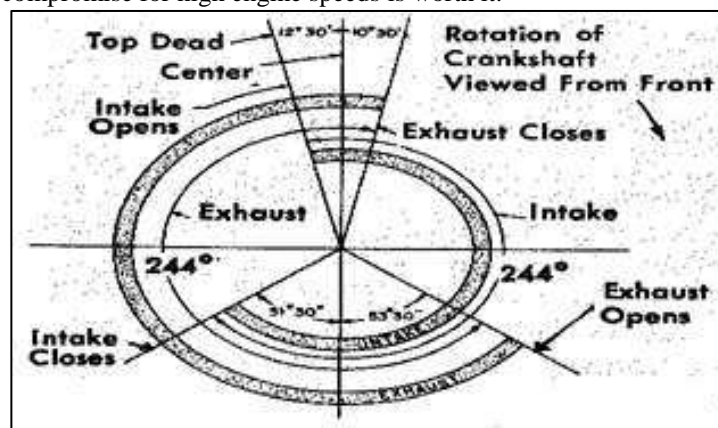

Fig. 4: Valve Timing Diagram

C. Ignition System

The engine comes with a Magnetic Breakerless distributor that uses mechanical weights for timing advance (maximum of 32 degrees). This system is mechanically linked to the engine through a gear on the camshaft. Each time the camshaft completes one revolution the rotor of the distributor also makes one revolution. On the same shaft as the rotor are 8 vanes, one for each cylinder.

- Each time one of these vanes pass by the magnetic pick up sensor on the distributor, the coil (single) discharges, sending a high voltage signal through the coil wire to the distributor. This signal would then be distributed to the proper cylinder via the rotor, rotor cap and spark plug wire. This type of ignition system works well for engines that do not have an Engine Control Computer (ECC).

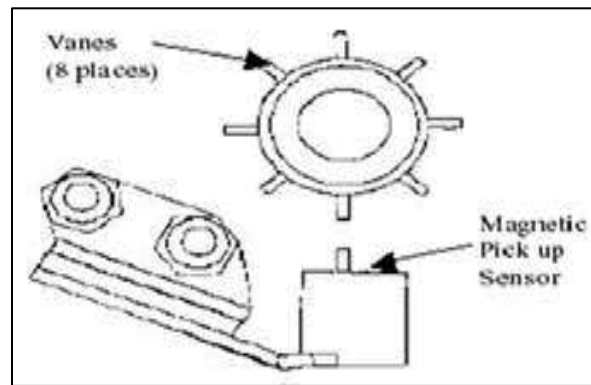

Fig. 5: View Distributor Vanes

D. Exhaust Emissions

Table – 1
Exhaust Emission

<i>Exhaust emissions –Total oxides of nitrogen (Otto – spark ignition engine)</i>		
<i>*Fed. Req.</i>	<i>3.0 gms/mi.</i>	<i>345 gms/10⁶ BTU</i>
<i>*Fed. Req.(a)</i>	<i>0.4 gms/mi.</i>	<i>46 gms/10⁶ BTU</i>
<i>Petroleum-Gasoline(b)</i>	<i>2.3 gms/mi.</i>	<i>265 gms/10⁶ BTU</i>
<i>*Methanol</i>	<i>0.37 gms/mi.</i>	<i>43 gms/10⁶ BTU</i>
<i>*Hydrogen(c)</i>	<i>2.04 gms/mi.</i>	<i>235 gms/10⁶ BTU</i>
<i>*Hydrogen(d)</i>	<i>0.2 gms/mi.</i>	<i>23 gms/10⁶ BTU</i>
<i>*Hydrogen(e)</i>	<i>0.02 gms/mi.</i>	<i>2 gms/10⁶ BTU</i>

- Advancements in engine technology have resulted in the virtual elimination of pollution from hydrogen-powered automobiles. Since no carbon is present in a hydrogen fuel system, hydrocarbon and carbon monoxide pollution do not exist. However, when the air, consisting of nitrogen and oxygen, is heated inside the engine, nitric oxide pollution is formed.
- Using water induction technique, peak combustion temperatures inside the hydrogen engine can be maintained at levels below the threshold for nitric oxide formation. This results in a substantial decrease in nitric oxide formation.

1) Properties of Hydrogen as alternative fuel

Table – 2
Combustion properties of hydrogen & Gasoline

<i>Property</i>	<i>Hydrogen</i>	<i>Gasoline (Petrol)</i>
<i>Molecular weight</i>	<i>2.02</i>	<i>91.4</i>
<i>Limits of flammability in air, vol.%</i>	<i>4.0-75.0</i>	<i>1-7.6</i>
<i>Stoichiometric composition in air, vol.%</i>	<i>29.53</i>	<i>1.76</i>
<i>Minimum energy of ignition in air, MJ.</i>	<i>.02</i>	<i>.24</i>
<i>Auto-ignition temperature, K.</i>	<i>858</i>	<i>501-744</i>
<i>Flame temperature, K</i>	<i>2318</i>	<i>2470</i>
<i>Burning velocity at NTP in air, cm s⁻¹</i>	<i>265-325</i>	<i>37-43</i>
<i>Quenching gap at NTP in air, cm.</i>	<i>0.064</i>	<i>0.2</i>
<i>Diffusivity in air, cm² s⁻¹</i>	<i>0.63</i>	<i>0.08</i>
<i>Limits of flammability (equivalence ratio)</i>	<i>0.1-7.1</i>	<i>0.7-3.8</i>
<i>Density at 1 atm. & 300K, kg m⁻³</i>	<i>0.082</i>	<i>5.11</i>
<i>Lower Heating value, MJ kg⁻¹</i>	<i>119.7</i>	<i>44.79</i>
<i>Lower Heating value, MJ m⁻³</i>	<i>10.22</i>	<i>216.38</i>
<i>Ratio of specific heat at NTP</i>	<i>1.383</i>	<i>1.05</i>

IV. HYDROGEN PRODUCTION

A. Hydrogen Generation

A system for generating hydrogen gas by electrolysis of water for fueling an engine is disclosed. The system comprises a power regulator to regulate the flow of an electric current from a battery source to a water tank provided in communication with engine. The water tank has a positive side and a negative side defined by a partition plate, each of the positive side and the negative side include a plurality of electricity conductors. The electricity conductors on the positive side receive the electric current in the water tank, on passing the electric current the water in the water tank undergoes electrolysis to generate oxygen gas at the positive side and hydrogen gas at the negative side, the hydrogen gas is then supplied to the engine via the hydrogen flow path.

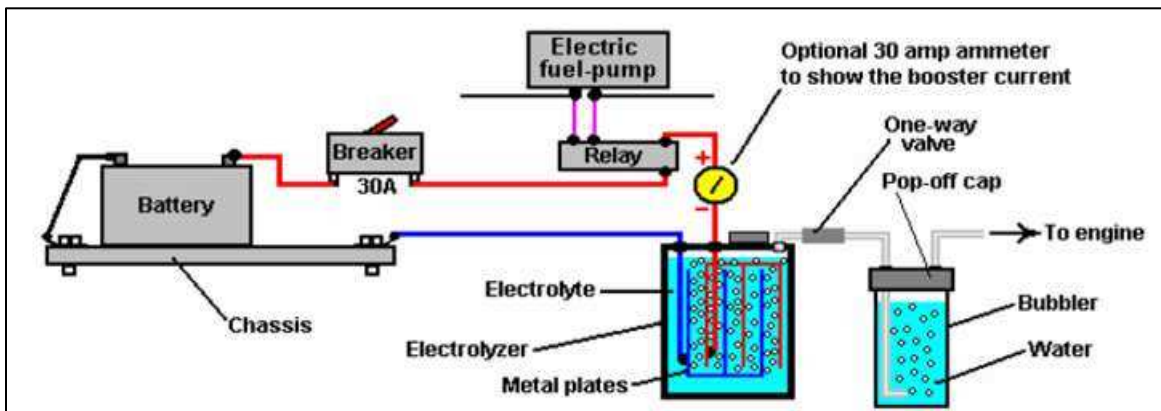

Fig. 6: Electrolysis process for hydrogen generation

B. Hydrogen Storage

1) Compressed Gas and Liquid Hydrogen Tanks

- Traditional compressed hydrogen gas tanks are much larger and heavier than what is ultimately desired for light-duty vehicles. Researchers are evaluating light-weight, safe, composite materials that can reduce the weight and volume of compressed gas storage systems. Liquefied hydrogen is denser than gaseous hydrogen and thus it contains more energy in a given volume. Similar sized liquid hydrogen tanks can store more hydrogen than compressed gas tanks, but it takes energy to liquefy hydrogen.
- Gasoline tanks used in cars and trucks today are considered conformable and take maximum advantage of available vehicle space. Researchers are evaluating concepts for conformable high-pressure hydrogen tanks as an alternative to cylindrical tanks, which do not package well in a vehicle.

2) Materials-Based Storage

- Hydrogen atoms or molecules bound tightly with other elements in a compound (or potential storage material) may make it possible to store larger quantities of hydrogen in smaller volumes at conditions that are within the practical operational boundaries of a polymer electrolyte membrane (PEM) fuel cell.
- Hydrogen storage in materials offers great promise, but additional research is required to better understand the mechanism of hydrogen storage in materials under practical operating conditions and to overcome critical challenges related to capacity, the uptake and release of hydrogen (i.e., kinetics), management of heat during refueling, cost, and life cycle impacts.

3) Safety Precautions of Hydrogen Gas

- Hydrogen is odorless, colorless and tasteless, so most human senses won't help to detect a leak. However, given hydrogen's tendency to rise quickly, a hydrogen leak indoors would briefly collect on the ceiling and eventually move towards the corners and away from where any nose might detect it. For that and other reasons, industry often uses hydrogen sensors to help detect hydrogen leaks and has maintained a high safety record using them for decades. By comparison, natural gas is also odorless, colorless and tasteless, but industry adds a sulfur-containing odorant, called mercaptan, to make it detectable by people. Currently, all known odorants contaminate fuel cells (a popular application for hydrogen). Researchers are investigating other methods that might be used for hydrogen detection: tracers, new odorant technology, advanced sensors and others.

V. SELECTION & SPECIFICATION OF HHO KIT

A. Construction of HHO Kit

- An HHO kit is a piece of scientific equipment that splits polarised molecules into its ions. In this case it will split water into hydrogen and oxygen gas. A dry cell HHO kit is an HHO kit that is completely enclosed; the other type is a wet cell HHO kit which can be two metal plates in a bowl of water. The equipment is fairly simple but the theory behind it is a bit more complicated.
- The HHO kit uses the different ionic charge on the different atoms in the molecule to split it into its respective charged atoms or molecules, for example, water gets split into Hydrogen and Oxygen because in the water molecule the hydrogen is slightly positively charged and the oxygen is slightly negatively charged. These charges are only very slight, +1 electron volt (ev) for each hydrogen and -2 ev on each oxygen atom. Just for comparison 1 electron volt is 1.6×10^{-19} Coulombs (c) and 1 Coulomb is the charge transported by a steady current of one ampere in one second. The hydrogen is attracted to the negatively charged electrode or Cathode and the oxygen is attracted to the positively charged electrodes or Anodes. At the anodes the oxygen ions loose an electron and bond to form oxygen gas, at the cathodes the hydrogen ions get an electron

from the cathode and then bond to form hydrogen gas. This transfer of electrons from and to the electrodes completes the circuit and allows current to flow. A catalyst can be used to make the process more efficient by reducing the energy needed to start the process; the catalyst that I use is KOH in a 1 to 40 mix with deionized water. The water doesn't need to be deionized but it extends the lifetime of the unit as minerals and other stuff won't build up on the electrodes.



Fig. 7: Construction of HHO kit

B. Working of HHO Kit

- An electrolyzer uses the process of electrolysis to change water into hydroxy gas. (hydrogen and oxygen or hho gas) It consists of electrodes that produce hydroxy gas when submerged in water made conductive with electrolyte, such as potassium hydroxide. Electrical current from the vehicle's battery is then applied. A substantial amount of hydroxy gas must be produced by an electrolyzer to make the combustion process more efficient. The standard of gas production is measured in liters per minute. (LPM). The hydroxy gas output of the electrolyzer is routed to the vehicle's air intake and vacuum intake manifold. The smaller molecules of the hydroxy gas strike the larger pre-heated gasoline molecules, breaking down the covalent bonds even further and atomizing the gasoline, while adding a combustible catalyst.

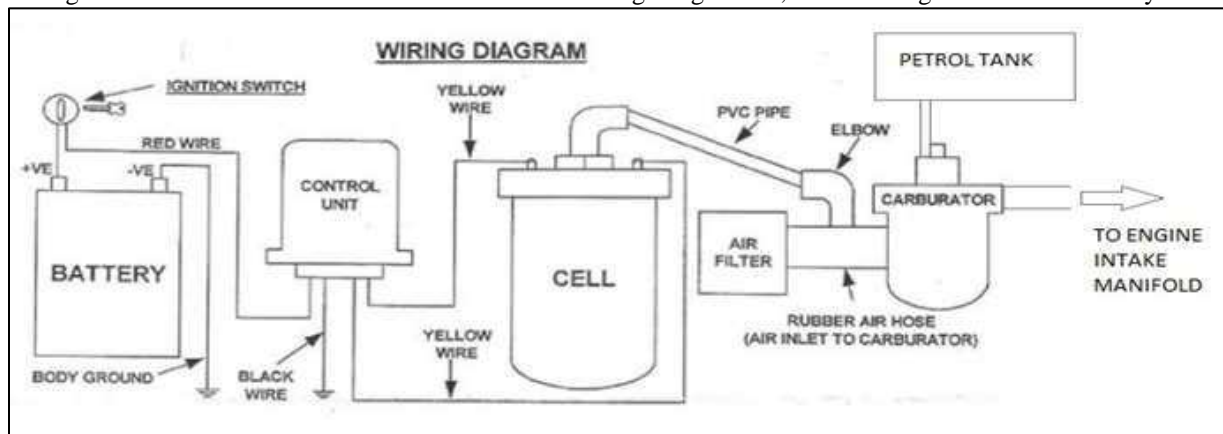

Fig. 8: Arrangement of SI engine with HHO kit

- Firstly switch ON the ignition so the power supply from battery to control unit. Control unit convert power AC to DC. Then this power is supply to fuel cell. Now, by electrolysis process of water produce hydrogen gas. Hydrogen gas is supply to carburetor through PVC pipe as shown in figure.
- In the carburetor the petrol which is come from petrol tank, hydrogen come from fuel cell and air is come from atmosphere through air filter. In the carburetor petrol, hydrogen and air are mixed. The percentage by volume of hydrogen and air is 20% and petrol 80%. This mixture from carburetor is supply to the engine intake manifold as shown in figure-8.

1) Emission Analysis

- A Scott exhaust gas analysis system, Model 108-H, was used to measure emission levels. This system consists of no dispersive infrared measurements for carbon monoxide and carbon dioxide emissions. Flame ionization methods were used to determine hydrocarbon emissions; the concentrations were measured in parts per million of equivalent propane gas. The nitric oxide (NO) emissions were measured with chemiluminescent techniques, and the oxygen concentration was measured by using paramagnetic effects. Known concentrations of gases were used to check the accuracy and calibrate the various constituents of the emissions measurement system. Several operational techniques were established to ensure good accuracy and trouble-free operation. First the sample line was heated to 450 K (350' F). Also, the internal sample lines used

to measure the hydrocarbon and NO, emissions were heated to 433 K (320° F). As part of the effort to avoid hydrocarbon and nitrogen dioxide (NO₂) dropout due to moisture removal, these emissions levels were determined on a wet basis. This technique eliminated contamination in the system. Finally, the converter used to convert NO₂ to NO was made of molybdenum in order to achieve high conversion efficiencies, as noted in reference 19. A stainless-steel converter had given erroneously low emissions readings because of its very low efficiency in converting NO₂ to NO. The system precision for all emission components was ±5 percent.

- The hydrocarbon, carbon monoxide, carbon dioxide, and oxygen concentrations were used to determine the experimental fuel-air ratio based on the Spindt method. This calculation provides a check on the measured fuel and air mass flow rates. The measured fuel-air ratios and the values calculated by the Spindt method differed by 4 to 5 percent, with the Spindt value being consistently high at both rich and lean conditions.

Table – 3
Emission analysis of 150cc SI Engine

Tested fuels	CO (% by vol)	HC (PPM)	CO ₂ (% by vol)	Throttle Position
Petrol	3.54	378	4.18	1(neutral gear)
Petrol-HHO	3.40	343	3.90	1(neutral gear)
Petrol	3.90	160	10.20	2(neutral gear)
Petrol-HHO	3.30	82	8.55	2(neutral gear)

2) Performance Analysis

- As per conducted performance analysis on Petrol-HHO engine by supplying petrol and Petrol + HHO fuels respectively. After analysis it has been found that the specific fuel consumption, brake power and the thermal efficiencies are increased with the Petrol + HHO fuel. The reading and graphs are shown below table and figure.

Table – 4
Performance analysis without HHO for 150cc SI Engine

Throttle position	Drum Speed (rpm)	Engine speed	fuel consumed (sec)	BP (KW)	η _{th} (%)	SFC (Kg/KW-hr)
1/8	406	1567	48	1.45	15.16	1.272
1/4	897	3465	37.50	3.15	24.09	0.765
1/2	1209	4674	34.50	4.47	34.02	0.570
3/4	1663	6430	33	6.15	43.05	0.440
1	2109	7152	19.50	7.80	33.45	0.570

Table – 5
Performance analysis with HHO for 150cc SI Engine

Throttle position	Drum Speed (rpm)	Engine speed	fuel consumed (sec)	BP (KW)	η _{th} (%)	SFC (Kg/KW-hr)
1/8	450	1752	54	1.60	18.60	1.015
1/4	961	3715	42	3.34	30.30	0.600
1/2	1300	5022	40	4.80	42.20	0.470
3/4	1705	6465	37	6.50	50.50	0.365
1	2230	8630	25	8.30	38.60	0.485

3) Pollution under Control Analysis

Table – 6
PUC Analysis without HHO kit

Sr. No	CO	HC	CO ₂	O ₂
1	0.270	619	5.42	20.98

Table – 7
PUC Analysis with HHO kit

Sr. No	CO	HC	CO ₂	O ₂
1	0.151	420	5.11	24.95

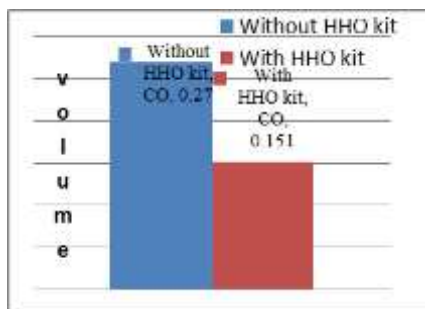

Fig. 9: Chart 1 PUC Analysis (CO)

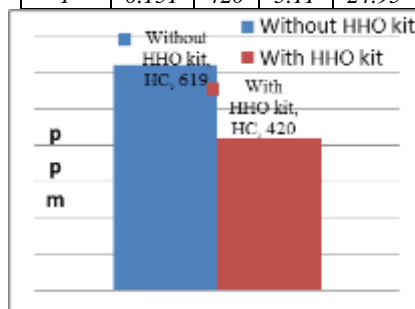

Fig. 10: Chart 2 PUC Analysis (HC)

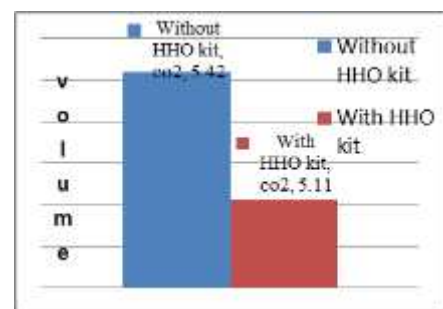

Fig. 11: Chart 3: PUC Analysis (CO₂)

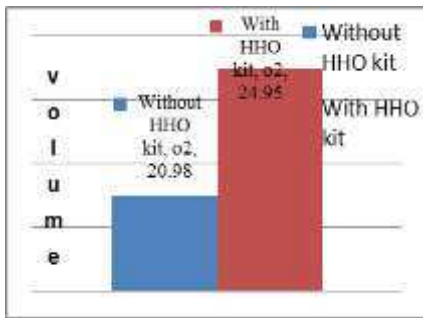

Fig. 12: Chart 4: UC Analysis (O2)



Fig. 13: Procution of Hydrogen



Fig. 14: Fitting of HHO kit

4) Mileage Measurement and Analysis

Table – 8
Mileage & Speed without HHO kit

Sr. no	Speed	Mileage
1	30	55
2	60	49
3	100	40

Table – 9
Mileage & Speed with HHO kit

Sr. No	Speed	Mileage
1	30	66
2	60	58
3	100	43

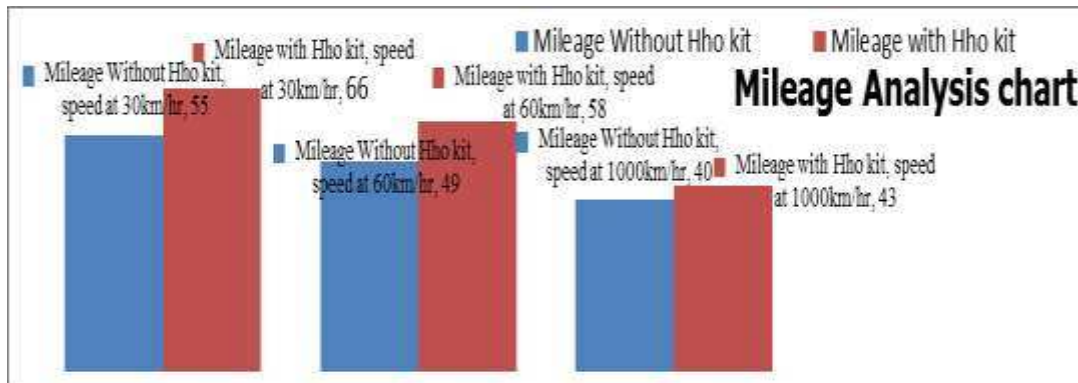

Fig. 15: Chart 5 Mileage Analysis Chart

VI. ADVANTAGES AND DISADVANTAGES

A. Advantages

- Eco-friendly and a clean fuel with products of combustion causing no severe environmental degradation.
- High specific energy of hydrogen per unit weight.
- In several respects superior to other fuels.
- Easy ignability of hydrogen.
- Wider flammability range.
- It is less hazardous than other fuels.
- Engine can be run on leaner mixtures.
- In certain respects hydrogen is safer than other fuels.
- Many heavy and bulky items.

B. Disadvantages

- Easy diffuse ability and lack of visibility make detectivity of leaking gas difficult.
- The equipment for storage is costly.
- Production may be polluting and costly.
- Pre ignition, backfiring and knock may occur.

VII. FUTURE DEVELOPMENTS

- There have been noted efforts in India in developing hydrogen as an alternative fuel. The US National Hydrogen Association is planning transition role of hydrogen as an interim measure before it could be finally accepted. The transition strategy is concerned with economics of hydrogen production, storage and transport, development of alternative captive fuel market, and selection of eco-friendly production systems and safety guidelines for the use of hydrogen as a fuel. California state authorities are reportedly trying to make hydrogen cars environmentally acceptable under a very stringent new exhaust emissions legislation which the state proposes to enforce strictly from 1997 onwards. It may still take several years of R&D efforts to make hydrogen vehicles competitive in performance and cost.

VIII. CONCLUSION

- Hydrogen is a very clean fuel which hardly leaves any deposits on engine parts. By this project we conclude that the mileage increase 25 percentage and decrease pollution. Also reduces engine noise and vibration. Fuel consumption is less. Exhaust contains more oxygen which is very useful for environment. Emissions from hydrogen engine are practically non-existent although some problems of nitrous oxide formation are encountered. Hydrogen is an ideal fuel for certain types of mobile applications. Hydrogen as a vehicular fuel may help to reduce dependence on fossil fuels in future.

REFERENCES

- [1] B.H. Khan (Non- conventional energy)
- [2] D. Ray (non-conventional energy)
- [3] Heat & Mass Transfer (P K Nag)
- [4] http://en.wikipedia.org/wiki/Hydrogen_fuel_enhancement
- [5] <https://www.google.co.in/search?q=%EF%83%98%09R.+Wang,+P.+Keast,+and+P.+Muir,+%22BACOL%3A+B spline+adaptive+COLlocation+software+for+1D+parabolic+PDEs,%22+Acm+Transactions+on+Mathematical+Software,+vol.+30,+pp.+454-470,+2004.&ie=&oe=#q=history+of+hydrogen+fuel+cell+vehicles>
- [6] <http://publications.lib.chalmers.se/records/fulltext/174167/174167.pdf>
- [7] Emissions of hydrogen cyanide from on-road gasoline and diesel vehicles Atmospheric Environment 131 (2016) 185e195 at www.sciencedirect.com
- [8] International journal of hydrogen energy 40(2015)4698e4706 "Effect of precooled inlet gas temperature and mass flow rate on final state of charge during hydrogen vehicle refueling" www.sciencedirect.com
- [9] International journal of hydrogen energy 36(2011)15803e15825 "Generation of high-pressure hydrogen for fuel cell electric vehicles using photovoltaic-powered water electrolysis" www.sciencedirect.com
- [10] College of Desert, "Module:3 Hydrogen use in Internal Combustion Engine ", Hydrogen Engines & Related Technologies, Rev.0, December 2001, CA 92260, USA.
- [11] Rohit Gulati, L.M. Das, P.K. Gupta, Centre for Energy Studies, Indian Institute of Technology, New Delhi. "A comparative evaluation of the performance characteristics of a spark ignition engine using hydrogen and compressed natural gas as alternative fuels International Journal of Hydrogen Energy, vol.25, pp. 783-793, 2000
- [12] Al Phillips, M.Sc., P.Ag. Allister Hickson, Ph.D., "Hydrogen Hybrid Internal Combustion Engine Bus Winnipeg Rider ship Survey." CFA, University of Manitoba Transport Institute, March 2005, USA.
- [13] Senthil KM, Ramesh A, Nagalingam B. Use of hydrogen to enhance the performance of a vegetable oil fuelled compression ignition engine. Int J Hydrogen Energy 2003.
- [14] Ganesh RH, Subramaniana V, Balasubramanianb V, Mallikarjuna JM, Ramesh A, Sharma RP. Hydrogen fuelled spark-ignition engine with electronically controlled manifold injection: an experimental study. Renew Energ 2008.
- [15] Liu Zhizhang, et al., Experimental investigations of hydrogen-gasoline mixed fuel for gasoline engines. Paper Presented at Beijing Int. Symp. for Hydrogen Energy (1985).